

Model ECLV30 - Vanguard Internal Halyard

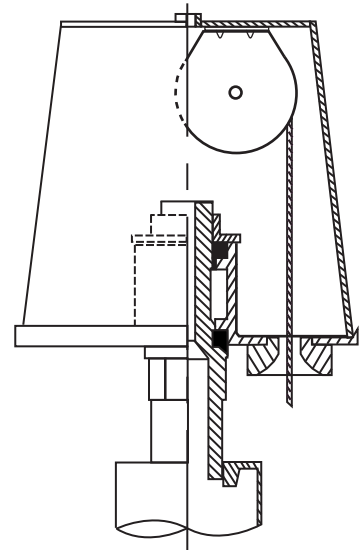

Revolving Internal Halyard Truck
 Cast aluminum body
 Enclosed stainless steel ball bearing and raceway
 Plated steel sheave

Reinforced, cast aluminum access frame mounted to shaft with 8, 1/4 20 x 1/2" stainless steel flat head screws.

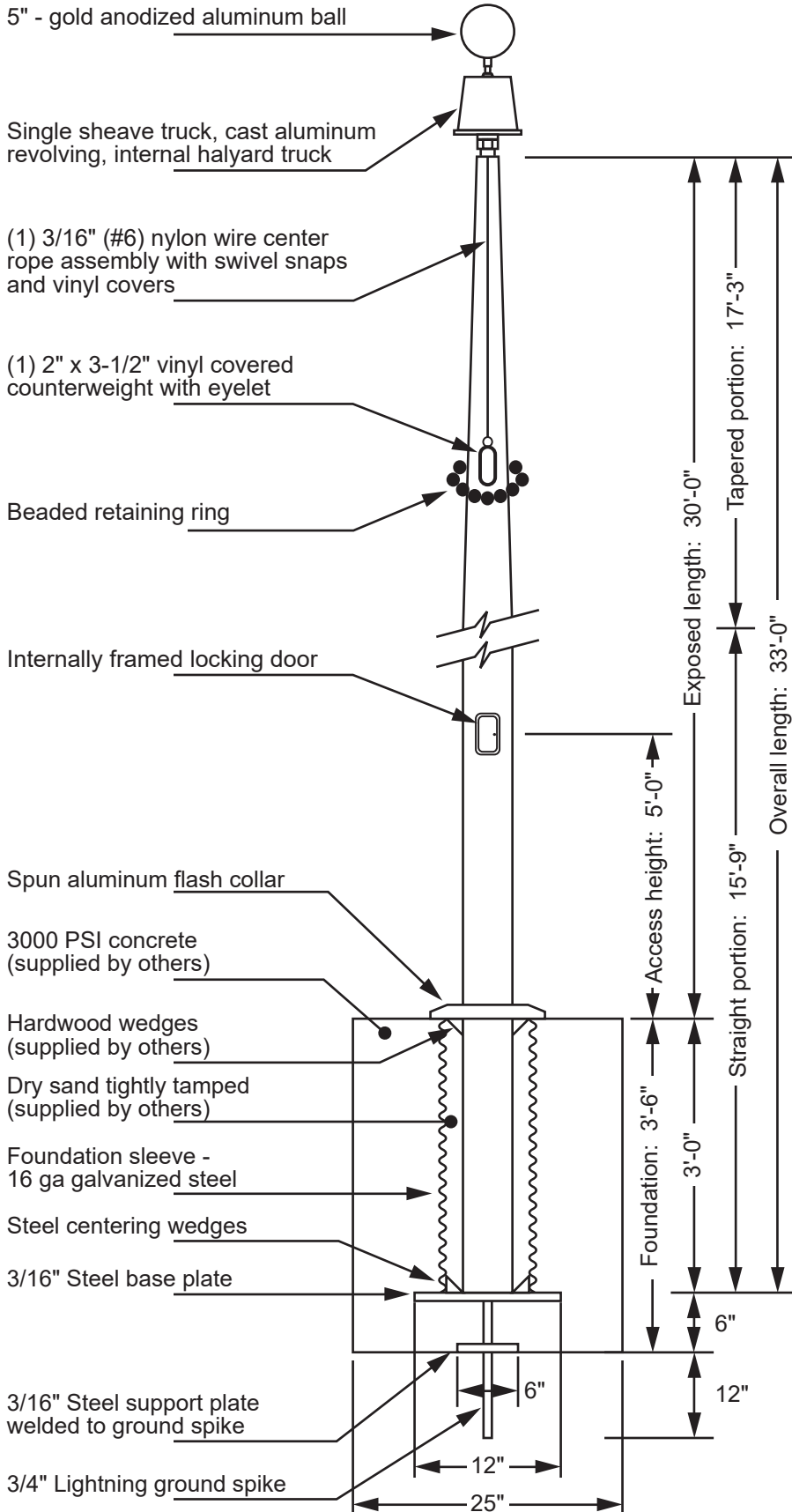
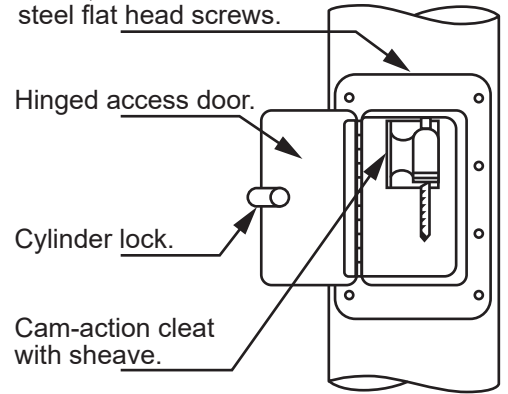

Project:
 Location:
 Contractor:
 Customer:

Date:
 Job:
 Revision:

Exposed Height ___ 30'-0"
 Overall Height ___ 33'-0"
 Butt Diameter ___ 5"
 Top Diameter ___ 3"
 Wall Thickness ___ .188"
 Ships in 1 section

Ground Set Tapered Aluminum Flagpole
 ALLOY 6063T6
 80 grit polish

FINISH:

