

# Model ECX25

5" - 14 gauge spun aluminum ball  
gold anodized

Single sheave truck, cast aluminum  
revolving, non-fouling type

2 Bronze swivel snaps with covers  
per halyard

1 Set of halyard: #10 poly

1 - 9" Cast aluminum cleat

Aluminum flash collar

3000 PSI concrete

Hardwood wedges  
(supplied by others)

Dry sand tightly tamped  
after aligning pole

Foundation sleeve -16 ga  
hot dip galvanized steel

Steel centering wedges

1/4" Steel base plate

1/4" Steel support plate  
welded to grounding spike

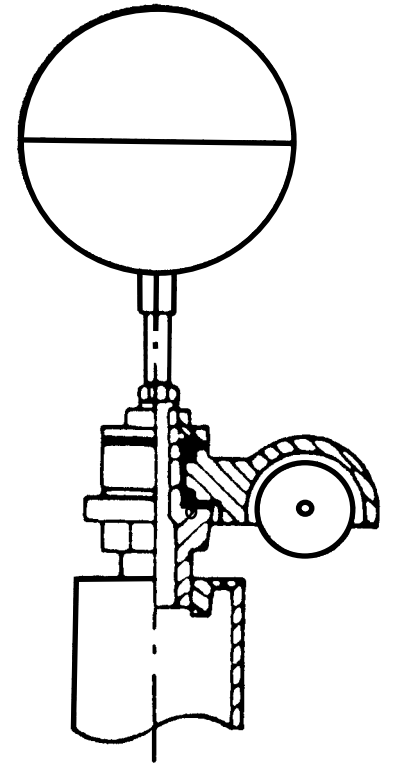
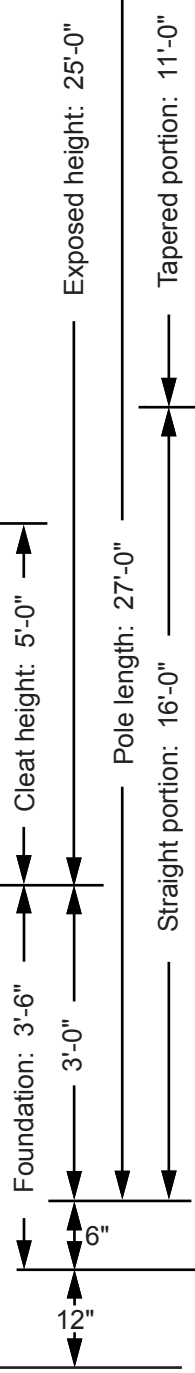

**Truck Detail**

Aluminum body  
Stainless steel ball bearings  
Aluminum sheave  
Cast aluminum spindle

All shafts with overall  
length of more than  
38'-6" are shipped in  
two sections.

Each section matched marked  
for field assembly. Exposed  
portion of jam sleeve must  
be **well lubricated** prior to  
assembly.

1-1/2" maximum shop  
gap allowed for field fitting  
(ram for tight joint)

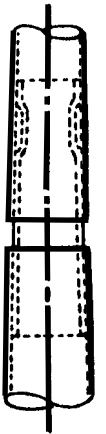

Project:	Ground set tapered aluminum flagpole: ALLOY: 6063T6		FLAGS.COM	Date:
Location:	Exposed height: 25'-0"	Pole length: 27'-0"	1-800-858-8776	Revision:
Architect:	Ship in 1 section	Butt diameter: 5"	1395 NW 17th Ave	
Contractor:	Top diameter: 3"	Wall thickness: .125"	Delray Beach, FL 33445	
Customer:	Finish: 100 grit polish			Job: