

Model EC25

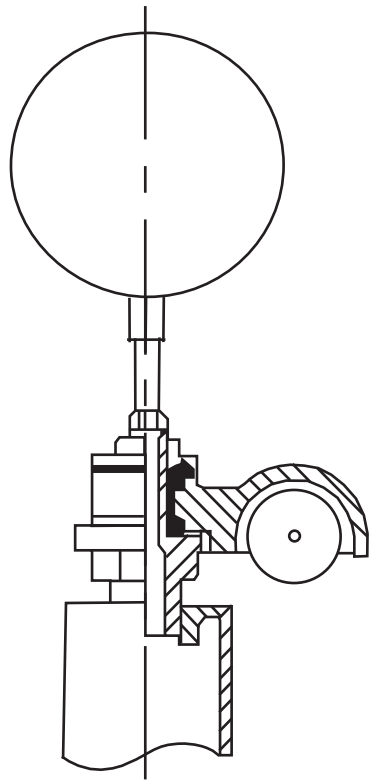
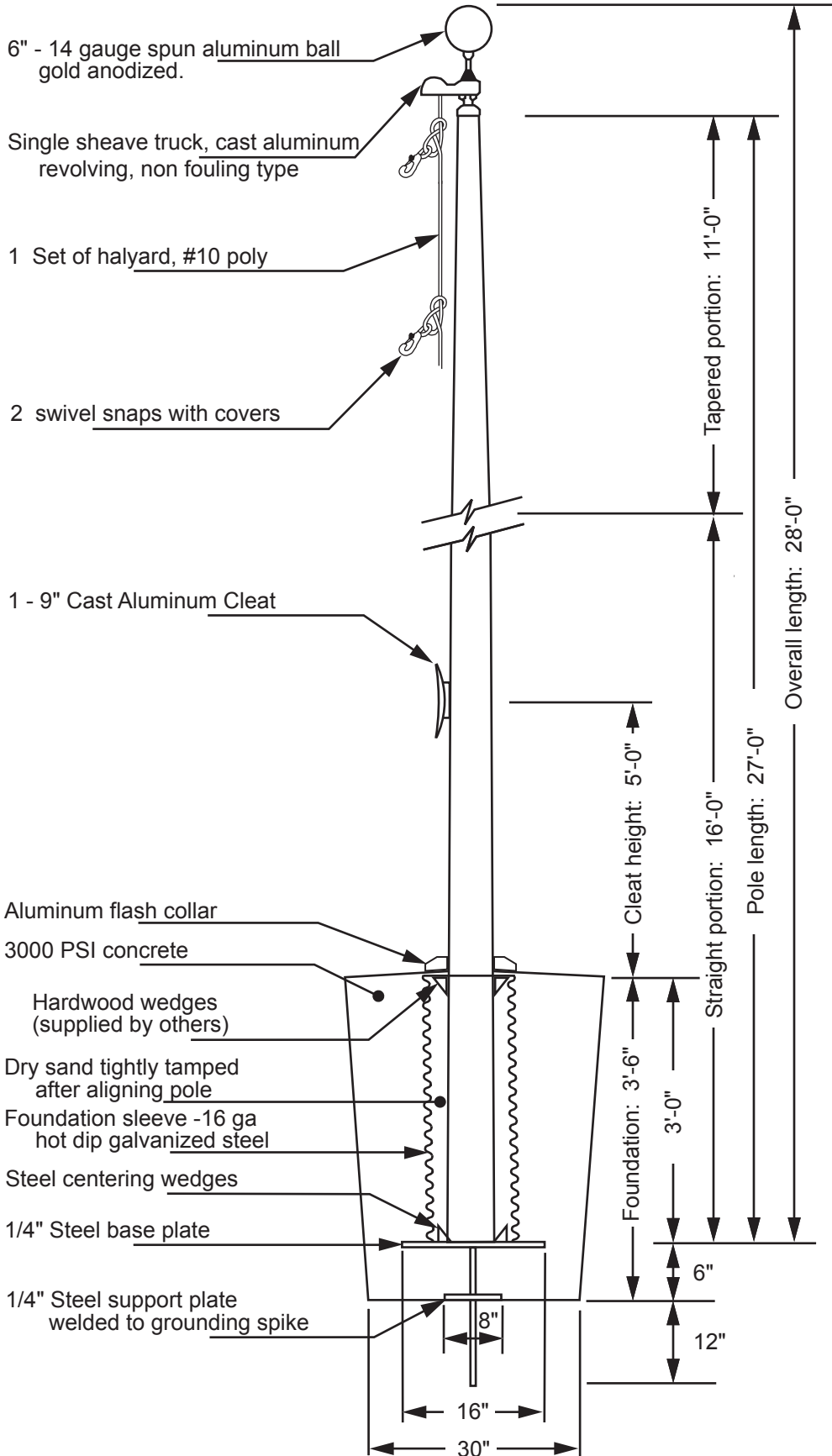

Truck Detail
 Aluminum body
 Stainless steel ball bearings
 Aluminum sheave
 Cast aluminum spindle

All shafts with overall length of more than 38'-6" are shipped in two sections.

Each section matched marked for field assembly. Exposed portion of jam sleeve must be **well lubricated** prior to assembly.

1-1/2" maximum shop gap allowed for field fitting (ram for tight joint)

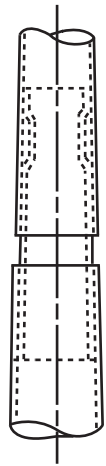

Project:	Ground set tapered aluminum flagpole: ALLOY: 6063T6	FLAGS.COM	Date:
Location:	Exposed height: 25'-0"	Overall height: 28'-0"	1-800-858-8776
Architect:	Ship in 1 section	Butt diameter: 6"	1395 NW 17th Ave #112B
Contractor:	Top diameter: 3-1/2"	Wall thickness: .188"	Delray Beach, FL 33445
Customer:	Finish: 100 grit polish		Job: